

DJ series

OPERATION MANUAL



SHINKO

Tokyo

CONTENTS

INTRODUCTION TO DJ SERIES.....	2
GENERAL SPECIFICATIONS.....	2
EXTERNAL VIEW & NAMES OF PARTS.....	3
MODELS.....	3
DISPLAY PANEL.....	4
KEY FUNCTIONS.....	4
INSTALLATION.....	5
1. Location.....	5
2. Unpacking.....	5
3. Loading Weighing Pan.....	5
4. Leveling.....	5
PERFORMANCE TEST.....	6
OPERATION.....	7
1. Taring & Weighing.....	7
2. To read Additional Weight.....	7
CONVENIENCES FOR USERS.....	8
1. Power Indicator.....	8
2. Bar Graph.....	8
3. Unstable Sign.....	8
4. Zero/Tare Indicator.....	8
5. Overload.....	8
VARIOUS FUNCTIONS.....	9
1. Items/Parameters/Contents.....	9
2. How to Verify Settings/Change Parameters.....	10
SPAN CALIBRATION.....	11
1. Span Calibration for DJ-E Models.....	11
2. Span Calibration for DJH-E Models.....	13
TROUBLESHOOTINGS.....	15
OPTIONS.....	16
1. Printer.....	16
2. Battery.....	17

° ° °

INTRODUCTION TO DJ SERIES

Your DJ model is a precision balance with high accuracy in the compact but robust body. The operation is very simple and its big LCD character ensures quick and reliable weighings.

Your DJ does not require any warm up time. Its Tuning-Fork sensor offers you most accurate result even just after energizing.

Please read this operation manual carefully before use.

GENERAL SPECIFICATIONS

Weighing Method : Tuning-fork frequency sensing method
Tare : 1.5% F.S. to Full Scale
Zero Tracking : Automatic zero tracking
Calibration : Semi-automatic calibration with reference weight, or with inner weight (DJH).
Temperature : -5°C to 35°C
Humidity : 80% r.h. or less
Display : Custom LCD of 16.5mm height
Power Source : Exclusive AC adaptor, or Built-in rechargeable battery operatble for 32 hours.(option)
Function : Ordinary weighing
Weight Units : g, ct, oz, lb
Options DJRP : Output for Shinko printers
DJR : RS232C output
Windshield
Carry Case
DJBT : Built-in rechargeable battery unit, operatble for 32 hours. Any output unavailable together DJBT.
Printers CSP-16 : Operation Micro Printer for ordinary roll paper.
CSP-193: Operation Printer for thermal roll paper, printing date.

Standard

Accessories : Opeartion manual, AC adaptor,

EXTERNAL VIEW & NAMES OF PARTS

DJ-150E, DJ-300E, DJ-600E, DJH-300E, DJH-600E

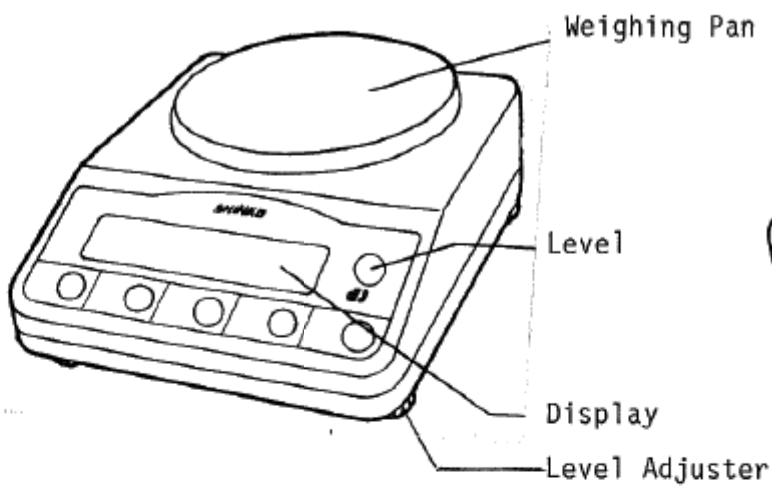

DJ-1500E, DJ-3000E, DJ-6000E

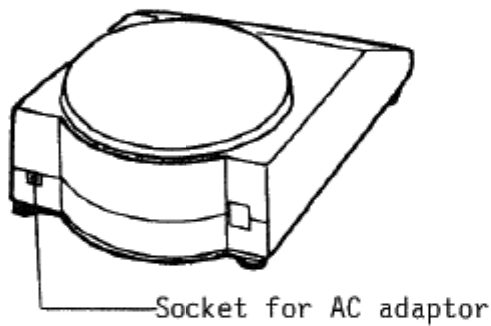

AC Adaptor

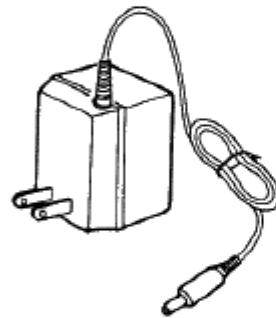



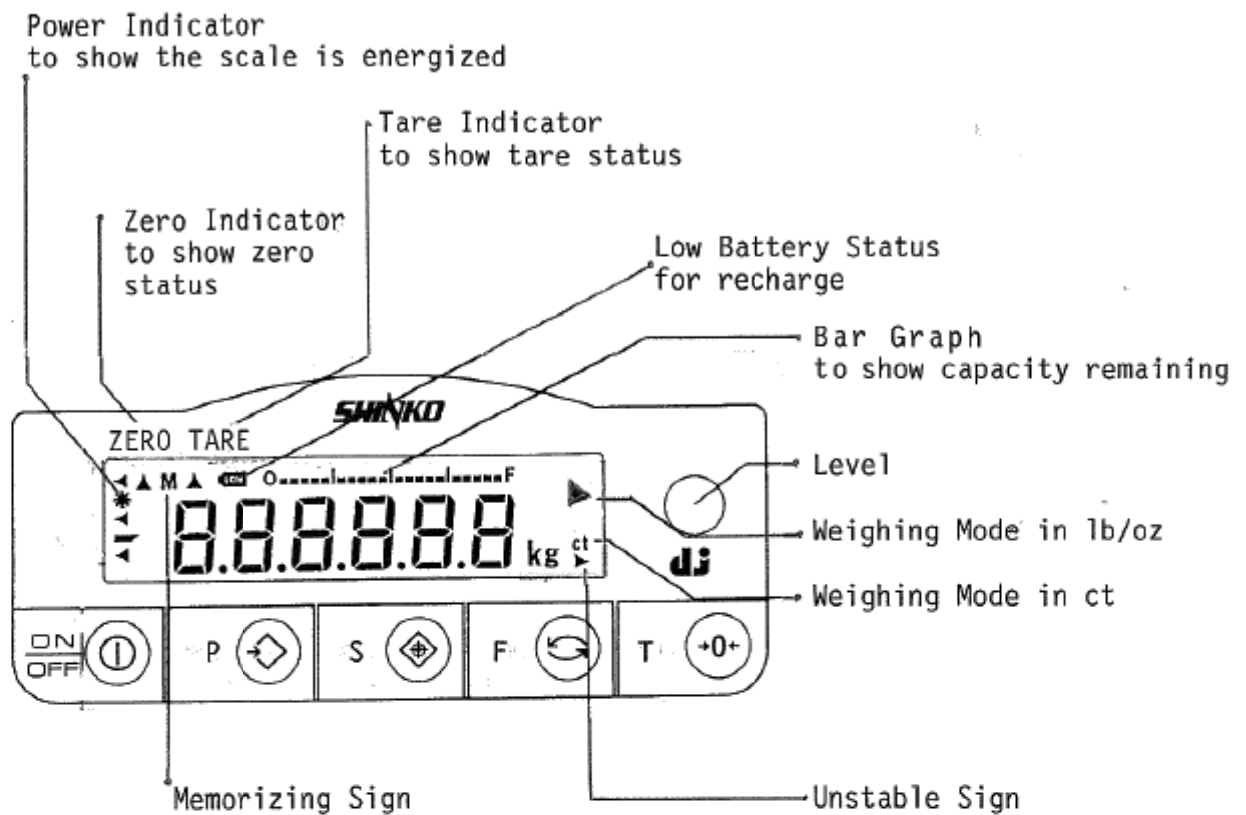

MODELS

MODEL	g		ct		lb/oz	
	Capacity	Division	Capacity	Division	Capacity	Division
DJ-150E	150g	0.01 g	750ct	0.05ct	5.2 oz	0.0005oz
DJ-300E	300g	0.01 g	1500ct	0.05ct	10 oz	0.0005oz
DJ-600E	600g	0.02 g	3000ct	0.1 ct	21 oz	0.001 oz
DJ-1500E	1500g	0.1 g	7500ct	0.5 ct	52 oz	0.005 oz
DJ-3000E	3000g	0.1 g	15000ct	0.5 ct	6.6 lb	0.00021lb
DJ-6000E	6000g	0.2 g	30000ct	1 ct	13 lb	0.00051lb
DJH-300E	300g	0.01 g	1500ct	0.1 ct	10 oz	0.001 oz
Auxiliary indication		0.001g		0.01ct		0.0001oz
DJH-600E	600g	0.01 g	3000ct	0.1 ct	21 oz	0.001 oz
Auxiliary indication		0.002g		0.01ct		0.0001oz

DISPLAY PANEL

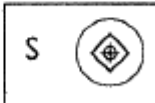

KEY FUNCTIONS

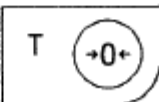
- 
 ON/OFF key for lighting display
- 
 Print key, or Data Transmission key
- 
 Set key, to finalize settings
- 
 Function key, to call various functions
- 
 Zeroing/Taring key
 Parameter selection key

INSTALLTION

1. LOCATION

VIBRA DJ scale is very robust, still it is a "precision weighing instrument" which requires gentle operation and handlings with care. Install the unit in good conditions for optimum result. Locations as followings may cause erroneous results.

1. Area having a soft floor to make the scale not level.
2. Area where temperature changes abruptly.
3. Area in high humidity or dusts.
4. On an unstable base or near to a source of vibration.
5. Area exposed to a wind from a fan or a cooler.
6. Area exposed to direct sunlight.

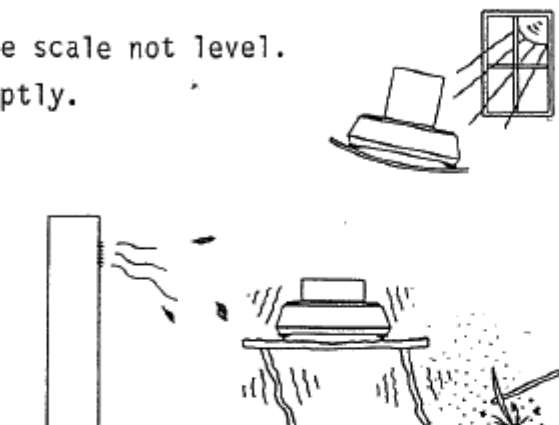

2. UNPACKING

Unpack the container carefully. Examine the packaging and the device for damage, and report to the shipper if any. Don't drop the scale. Check the enclosures as follows:

1. The scale
2. The weighing pan and the pan base
3. AC adaptor
4. Operation Manual

3. LOADING WEIGHING PAN

Place the pan base packed with the weighing pan on the scale. Fix it on the shaft by driving the knurled nut in the centre. Place the weighing pan properly on the pan base. See (a).

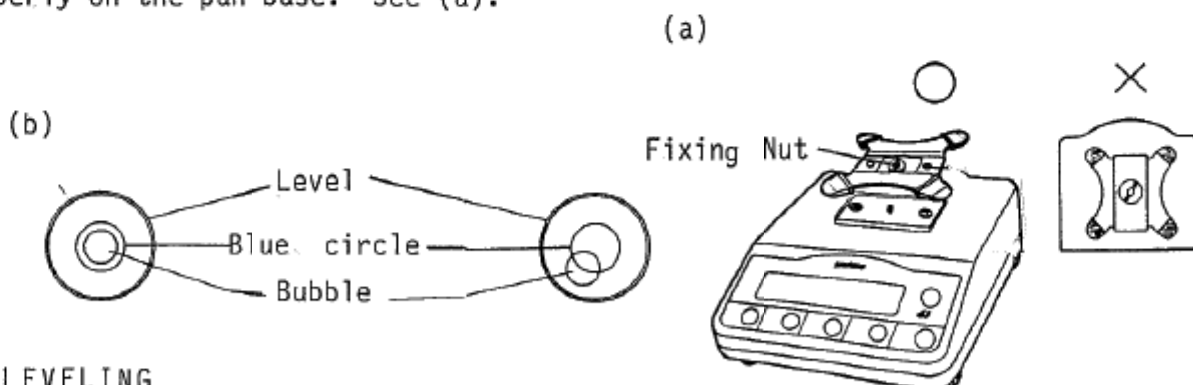

4. LEVELING

Watch if the scale is level. Locate the level in front of the scale, and four adjusting legs beneath it. Drive these legs to centre the bubble in blue circle of the level. Watch if all legs are settled on the table securely. See (b).

PERFORMANCE TEST

Connect the AC adaptor with the rear of the scale, then plug the cord in line outlet.

1 Press ON/OFF key

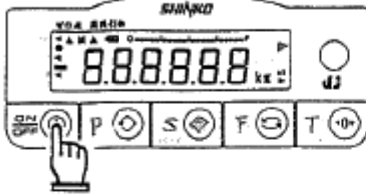

2 Verify all segments

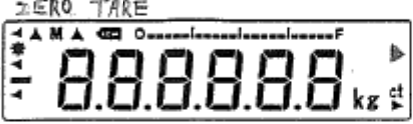

3 Changing weight unit

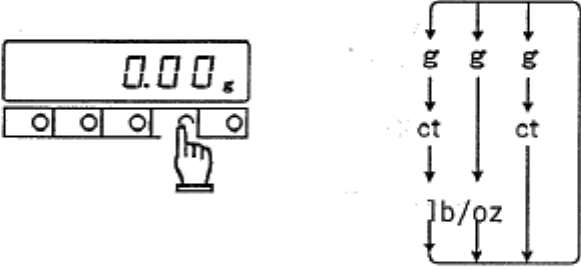

4 Verify response

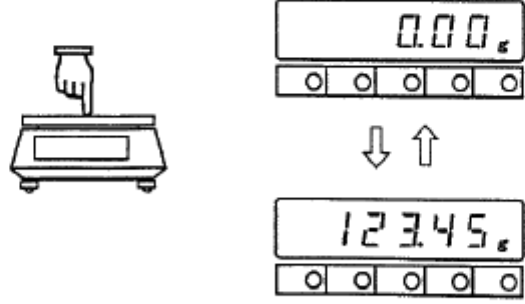

Press the ON/OFF key of the front panel to light the display on.

* If the lock switch is free, "Adj." appears once.

Verify that all the segments and characters light completely. Display changes to "0" in several seconds.

Press F key for three times to see the weight unit changes from "g" to "ct", then "▶" over it, and returns to "g", or two of those units. It depends on model.

"▶" is for lb/oz mode.

Verify that the display changes by touching the pan slightly, and that it returns immediately to the original by releasing it. The auxiliary division is provided only for your reference, it is not officially approved.

* Remark to Shinko distributors.

OPERATION

Warming up of DJ scale is almost unnecessary. 4 to 5 minute warming up will give you optimum result, however.

1. TARING & WEIGHING

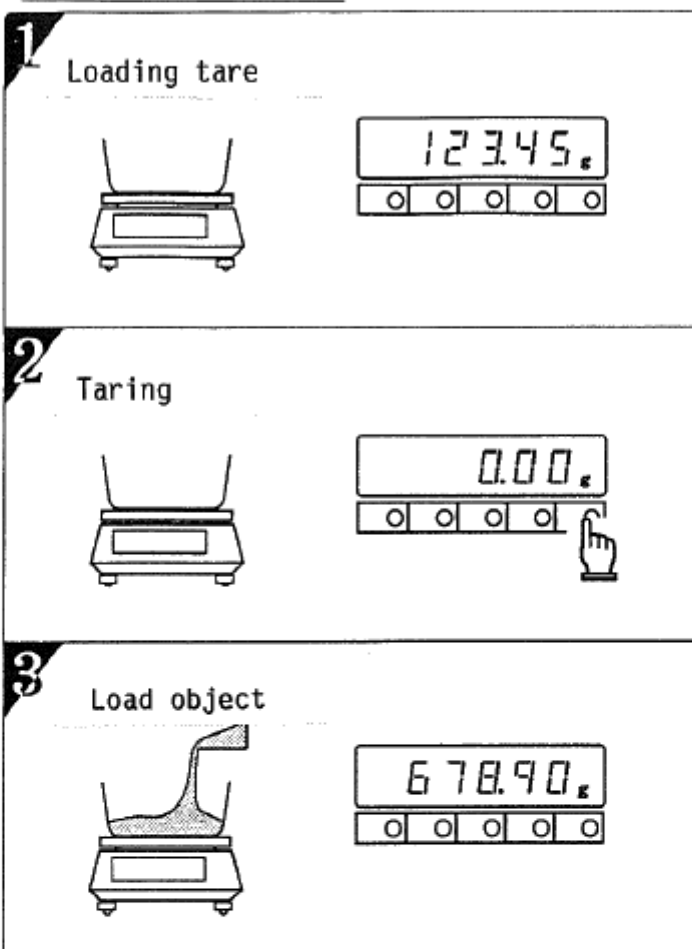

Place a container on the pan to read the weight value of it.

Press T key to tare and read "0".

By loading some objects in the container, the display shows the net weight value of the objects.

2. TO READ ADDITIONAL WEIGHT

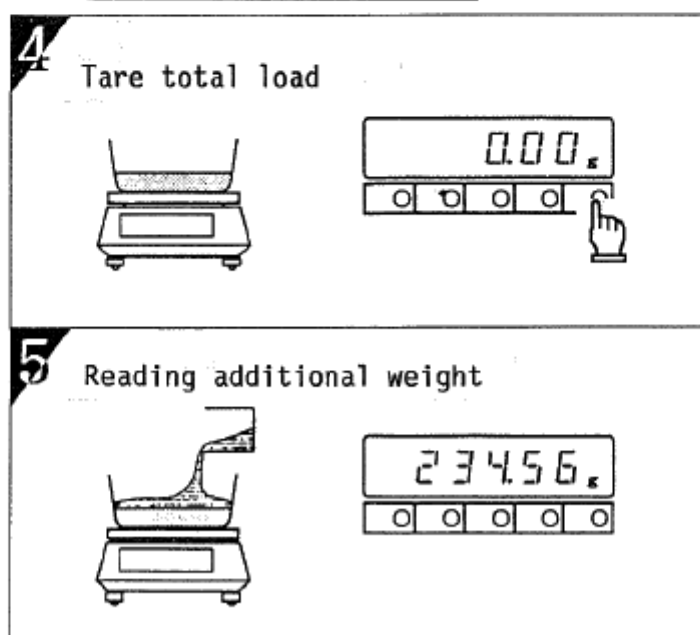

Press T key with the last object in the container, to read "0".

Add object in the container. The display shows the weight value of the addition.

CONVENIENCES FOR USERS

1. POWER INDICATOR

The * sign shows that the scale is energized through the AC adaptor. When the ON/OFF key is pressed to ON, it disappears.

It is recommended to unplug the AC adaptor when a daily operation finishes.

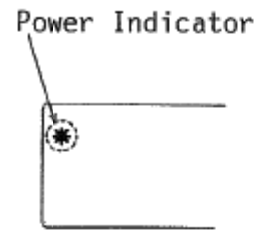

2. BAR GRAPH

The bar graph indicates remainder of capacity by 20 bars which increases according to load on the scale pan.

Even display shows "0" by taring, the bar graph indicates the weight value of the tare.



3. UNSTABLE SIGN

While a data is unstable, a "▶" sign appears in the right low corner of the display. Provide a windshield or else when it appears often.

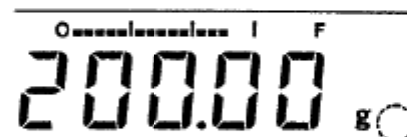
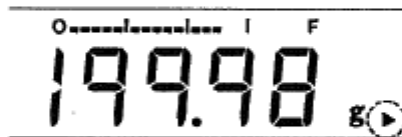

4. ZERO/TARE INDICATORS

When the scales is at true "0"

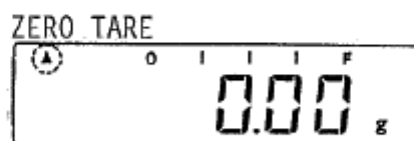

When the scale is at tared "0"

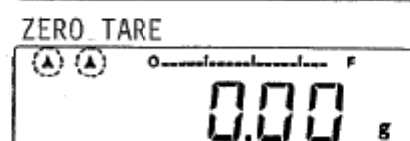

The Zero Indicator shows that the displayed "0" is at true zero, ie, within the tolerance of 1/4 division while the ▲ sign appears.

The Tare Indicator shows that the displayed "0" is at zero after tare by ▲ sign.

5. OVERLOAD

By taring, the measuring capacity is decreased.

$$\text{Weighing Range} = \text{Full Capacity} - \text{Tare Value}$$

The display "o-Err" indicates that the load is over the weighing range.

VARIOUS FUNCTIONS

1. ITEMS / PARAMETERS / CONTENTS

Functions	Display	Content
Bar Graph	1. BG 0 1 *	Bar graph is not displayed Bar graph is displayed.
Zero Tracking	3. ZO 0 1 *	Zero tracking is not effective. Zero tracking is effective.
Auto-Power off	4. AP 0 1 *	Auto-power off is not effective. Power turns off after 3 minutes. ***
Response Speed	5. RE 1 2 * 3	Quick response. Medium Slow response.
Output Control	6. OC 0 1 2 3 4 5 6 7 *	No data transmitted. Constant serial transmission. Serial transmission of stabilized data only. One transmission by command from printer. Auto-transmission with loading an object. One transmission of stabilized data only. One transmission when stabilized, serial for else. One stabilized data by command from printer.
Baud Rate	7. BL 1 * 2 3	1200 bps 2400 bps 4800 bps
Weight Unit	8. SE 1 * 2 3 4	"g" only g/ct switchable. g/oz(lb) switchable. g/ct/oz(lb) switchable.
Auxiliary Indication	9. AI 0 * 1	No auxiliary indication. (DJH-E) Auxiliary indication is effective. (DJH-E)
GLP Printing	0. GLP 0 * 1	No transmission for GLP printing (DJH-E) GLP printing transmission is effective. (")
** Format for Auxiliary Indication	A. P.F 1 2 3 *	No transmission of auxiliary indication. Standard format, while auxiliary indication. EN format, with "/" before the last digit in auxiliary indication. Ex.200.00/5

* Settings made when delivered from factory.

** Formats for Auxiliary Indication is effective when the lock switch is OFF, free. While the lock switch is ON, functions will not be displayed but the scale performs just as set when it was free.

*** In optional battery operation only.

2. HOW TO VERIFY SETTINGS / CHANGE PARAMETERS

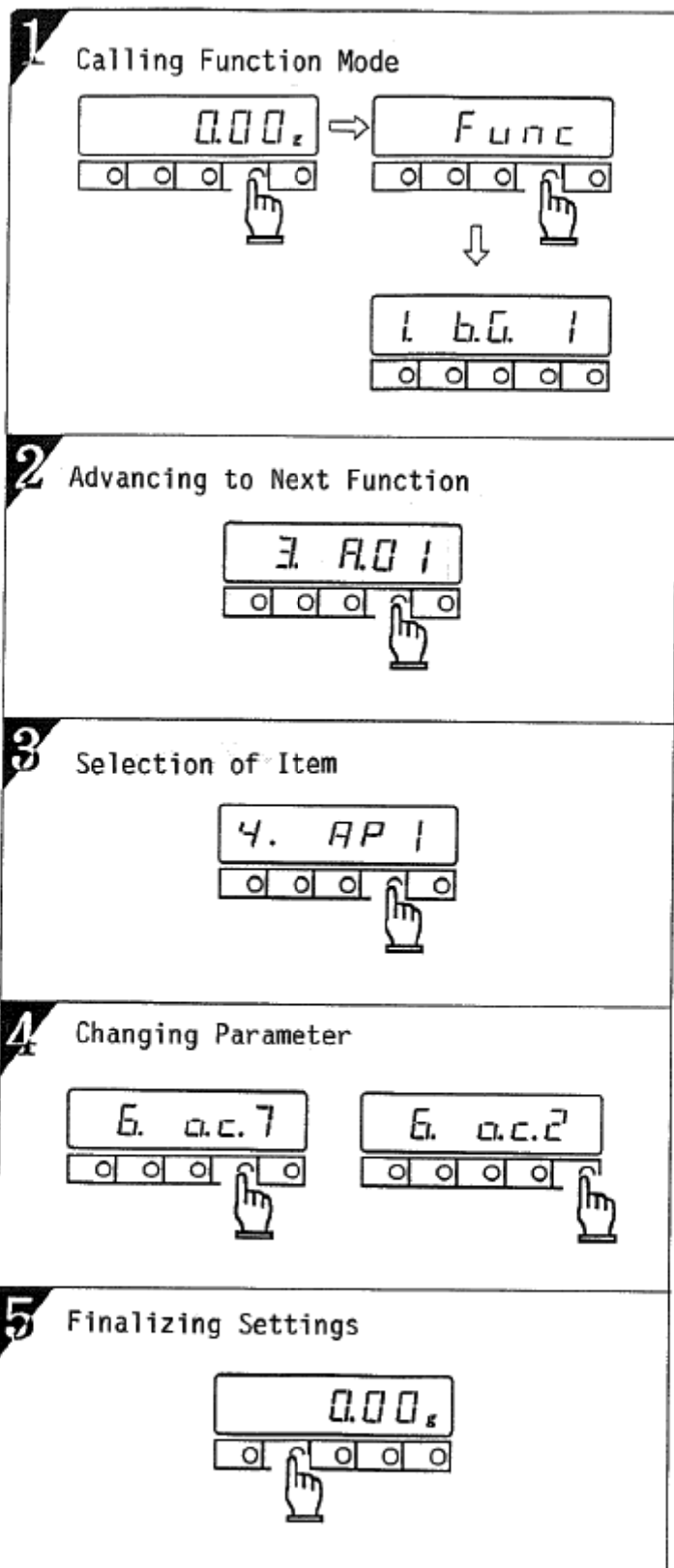

Press F key for about 4 seconds. Release it when display changes to "Func".

The mode is now in setting mode, displaying the first item "Bar Graph". See page 9.

Press F key to advance to next function, "Zero Tracking" in this case.

By pressing F key, item will advance to next one. Stop at the item to change the setting.

By pressing T key, the parameter will change. Select the suitable one for the work.

To stop the setting, press S key. Display will return to the weighing mode.

SPAN CALIBRATION

To achieve optimum accuracy from the scale, it should be calibrated in area it is used, and recalibrated when it is relocated to other area.

The SPAN CALIBRATION is unavailable with a DJ which is stamped or sealed by local Weights/Measurement office. When calibration is necessary, contact your dealer.

1. SPAN CALIBRATION FOR DJ-E MODELS

1 Calling Span Calibration Mode

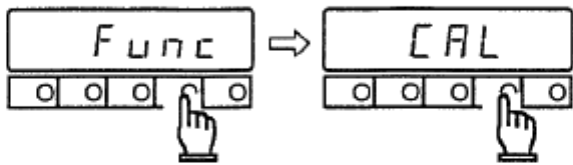

2 Starting Span Calibration

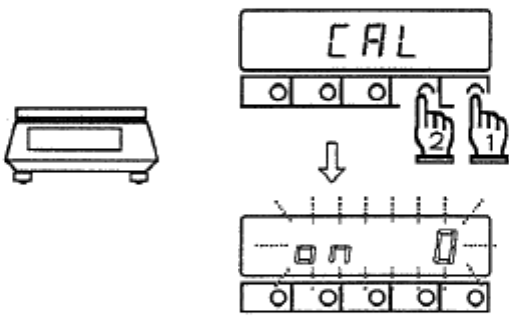

3 Zero Adjustment

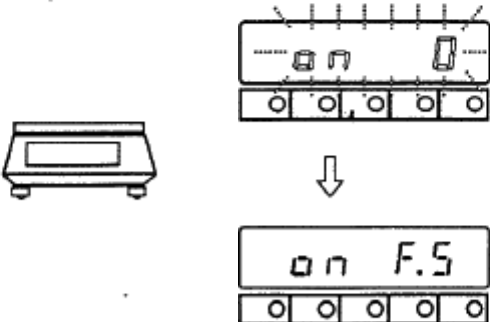

Press F key until "CAL" appears after "Func".

Press T key first and while pressing it, press F key together and release both. Display starts blinking "on 0" which indicates zero adjustment is automatically performed. Verify that no load is on the pan.

When zero adjustment is completed, display advances to "on F.S" which indicates the span adjustment is ready to start.

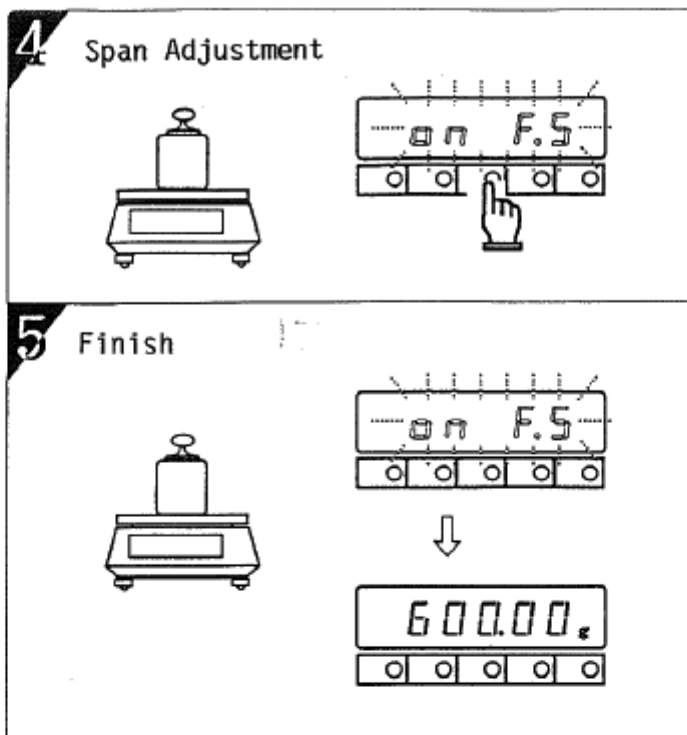

Apply prepared calibration weight* just in the centre of the weighing pan. The display will start blinking to adjust the span exactly.

When the calibration is completed, the display will return to the weighing mode.

Remarks

1. During Operation 2, if Fkey is pressed first, the mode will return to weighing.
2. The calibration is available with 1/2 of the scale capacity. Nevertheless, a calibration weight closer to F.S. is recommended to use for accurate calibration.
3. It is recommended to use a calibration weight of better accuracy than the division of the scale.
4. Problems in calibration performance will be displayed by any of following error messages, which disturbs the calibration. Check weight.

0 - E r r : The calibration weight is over the full capacity.

1 - E r r : The calibration weight is less than 1/2 of the capacity.

2 - E r r : The data error exceeds 0.4%. Or perhaps the scale may be defective. Contact the shipper.

2. SPAN CALIBRATION FOR DJH-E

Before calibration:

* Is the scale level? Make it level referring to page 5.

** Is the weighing pan empty?

1 Starting Span Calibration

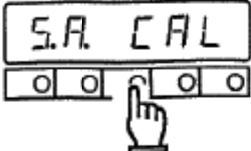

2 Automatic Zero Adjustment

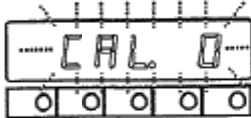

3 Completion of Zero Adjustment

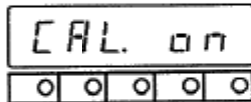

4 Span Adjustment

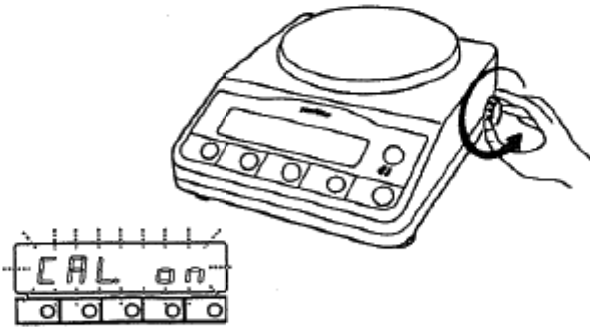

5 Completion of Span Adjustment

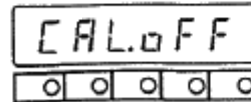

Press S key to start automatic calibration, displaying S.A. CAL.

Display starts blinking "CAL.0", which indicates zero adjustment is automatically performed.

Display changes to "CAL. on" which shows the mode advanced to span adjustment.

Turn the Calibration Knob gently to CAL (anticlockwise) until it stops.
Now the calibration weight inside has been loaded.
Display starts to blinking to indicate the span adjustment is automatically performed.

Display changes to "CAL. off" to indicate the span adjustment is over.

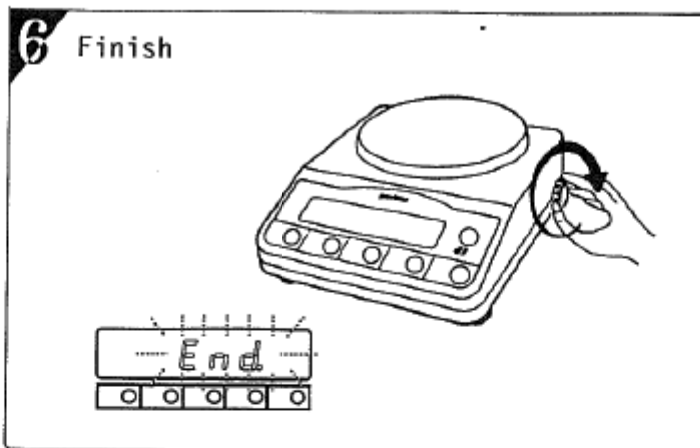

Return the Calibration Knob at WEIGH point by turning it gently until it stops with a slight sound.

Now the calibration weight inside has been unloaded to display "End."

Span calibration is finalized by indicating "0".

Remarks

1. During the Span Calibration procedure, pressing any other keys than ON/OFF will interrupt the operation showing "StOP".
2. The Calibration Knob should be turned gently, but don't stop until end. To CAL, it stops lightly. To WEIGH, it stops lockedly with a sound.
3. Keep the Calibration Knob at WEIGH except calibration. "CAL.oFF" appears if the power is turn on while it is at CAL, or if it is switched to CAL while weighing.
4. If the scale is affected by a wind or oscillation, the calibration will not advance after CAL.0. Provide a windshield or a stable base.
5. "3-Err" appearing after operation 2 indicates that the error at zero is too much from that of shipped from the factory. Check if something on the weighing pan.
6. "4-Err" appearing after returning the knob to WEIGH in operation 6 indicates that the error at span is too much from that of shipped from the factory. Check if something on the weighing pan.

If problem is not solved by removing load on the pan in above 5 and 6, contact the shipper.

TROUBLESHOOTINGS

SYMPTOMS	CAUSES & REMEDY
No display LOW blinks	<ul style="list-style-type: none"> * AC Adaptor is not connected, or ON/OFF key is pressed to OFF. * Power has been turn off automatically by auto-power off function (with battery option). Press ON/OFF key. * Battery has been consumed (with battery option). Connect the AC adaptor, charge the battery.
Display unstable	<ul style="list-style-type: none"> * Affected by a wind or oscillation. Check location and response speed function. * The installation base is unstable. Check the base. * Weighing pan or tare touches something. -Check.
Erroneous value reads in display	<ul style="list-style-type: none"> * Wrong tare operation. See page 7. * Scale is not level. See level, page 5. * The span has changed by relocation or after long time lapse. Calibrate the scale referring to page 11 through 14.
Unable to weigh upto capacity. a - E r r	<ul style="list-style-type: none"> * Gross weight of the load exceeds scale capacity. Weighing Range= Full Capacity - Tare value * No problem with tare... Mechanism is defective.
u - E r r	<ul style="list-style-type: none"> * Something contacts the weighing pan to lift it up. * No problem around the pan...Mechanism is defective.
b - E r r d - E r r	<ul style="list-style-type: none"> * Electronic error, by a static electricity or noise. * Electronic parts is defective. Contact shipper.
o - E r r 1 - E r r 2 - E r r 3 - E r r 4 - E r r	<ul style="list-style-type: none"> * The calibration weight is over the full capacity. * The calibration weight is less than 1/2 F.S. * The data error exceeds 0.4%. Or the scale may be defective. Contact the shipper. * Span calibration has started with a load on the pan. If the problem is not solved by clearing it up, the mechanism is defective. Contact shipper.

OPTIONS

1. PRINTER available with a scale provided with an interface option.

Connection with a Printer

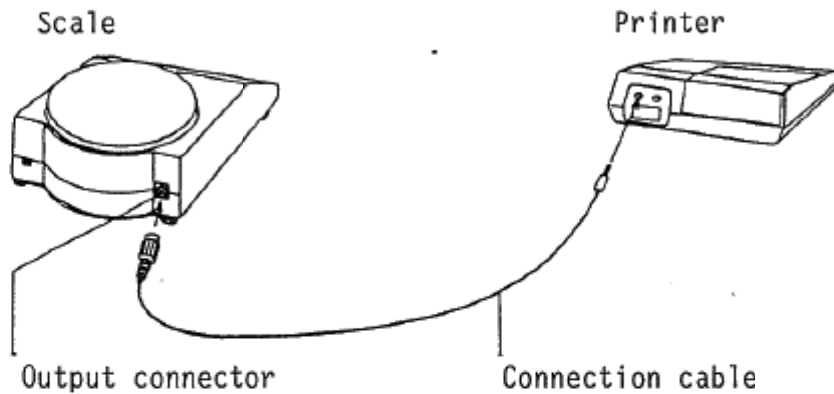

Settings of Function See page 9, Output Control and Operation Manual of the printer.

Printings corresponding to GLP

Using our printer CSP-16, GLP printing is available by following setting.

1. Set function "0. GLP" at "1". See page 9.
2. Set dip switch No.4 of the printer "ON". Refer to operation manual of CSP-16.

<u>PRINT SAMPLE</u>	<u>Items printed</u>	<u>Items to be written manually</u>
---------------------	----------------------	-------------------------------------

CALIBRATION	_____	Span Adjustment start
MODEL:	_____	Model Name of the scale
SER.NO:	_____	Serial No. of the scale
ID:	_____	ID No.
DATE:	_____	Date of calibration
TIME:	_____	Time of Calibration
*CAL.END	_____	Calibration finish
NAME:	_____	Name of operator

2. BATTERY available with a scale provided with a rechargeable battery unit.

Specifications

- | | |
|-------------------------------|-------------------------------------|
| * NiCd battery | * Charging hour : Approx. 12 hours |
| * Temperature/Humidity | * Operation hour: Approx 32 hours |
| 0°C to 35°C, 65% rh \pm 25% | * Chargeable times : over 300 times |

Battery option is unavailable to use an output option.

Recharging Battery level is indicated by blinks of **LOW**. Charge battery by following procedure.

1. Connect AC adaptor which is exclusive with Shinko scale.
2. Press the power key on the panel to OFF.
3. Leave the scale under this setting for about 12 hours to complete charging. Longer charging may damage the battery unit.

Remarks

1. When charging finishes, unplug the AC adaptor to prevent the battery from damage.
2. Charging before reading **LOW** sign may also damage the battery.

CAUTION

1. Dismantle or modification of battery, or erroneous wiring may damage the battery, and to cause problem on the scale.
2. Use the Shinko exclusive AC adaptor. Using other adaptor may cause heat or explosion of battery.
3. Don't put battery into fire or heat.